



# Bandit

**AUTHORIZED DEALER**

**SINCE 1983**



IMPORTED AND DISTRIBUTED BY



**AFRICA  
BIOMASS  
COMPANY**

[www.abc.co.za](http://www.abc.co.za)

## To our Valued Partners and Clients,

At ABC, our reputation is built on the strength of the promises we keep. In the demanding world of arboriculture, forestry, and recycling, those promises are only as strong as the machinery we deploy. This is why, when it comes to our own fleet and the equipment we recommend to you, we place our absolute trust in Bandit Industries.

Our relationship with Bandit is not merely a commercial one; it is a partnership forged in the field. We don't just supply these machines—we use them. We have seen firsthand how Bandit equipment handles the most gruelling conditions with an ease that others simply cannot match. Whether it is a hand-fed chipper or a massive horizontal grinder, the engineering philosophy remains the same: build it heavy-duty, keep it simple to maintain, and ensure it outworks everything else on the site.

We trust Bandit for three fundamental reasons:

- 1. Unmatched Durability** In this industry, downtime is the enemy of progress. Bandit machines are over-built to ensure they withstand the rigours of daily, high-volume use. This ruggedness translates directly to a lower total cost of ownership and a higher resale value for our clients.
- 2. Innovation with Purpose** Bandit does not innovate for the sake of complexity. Every feature, from the Slide Box Feed System to the specialised drum designs, is engineered to increase throughput and fuel efficiency. It is smart technology that works for the operator, not against them.
- 3. A Shared Commitment to Support** A machine is only as good as the support behind it. Aligning ABC with Bandit Industries means our clients benefit from a global legacy of parts availability and technical expertise. When you invest in a Bandit through ABC, you are securing a lifeline of support that ensures your operations never skip a beat.

When I look at our fleet today, I see more than just steel and engines; I see the reliability that allows our clients to grow their businesses with confidence. We stand behind Bandit because they have never failed to stand behind us.

Thank you for your continued trust in ABC. We look forward to powering your success for many years to come.

Sincerely,



Willem van der Merwe  
CEO, ABC

Bandit is one of the leading wood chipper brands worldwide. Bandit's performance and reliability, together with ABC's expertise and service, provide winning solutions to every customer. Bandit's chippers are adapted to local circumstances, and some of our models have up to 55% local content.

ABC is the authorised dealer for Bandit wood chipper in Africa.

## **PTO DRIVEN HAND-FED WOOD CHIPPERS**

Bandit's PTO hand-fed wood chippers are the perfect solution for companies seeking a compact and cost effective machine. Engineered for durability and performance, these chippers are built to meet the demands of the African landscape.

## **ENGINE DRIVEN HAND-FED WOOD CHIPPERS**

Bandit's range of engine-powered hand-fed wood chippers can be easily towed behind a bakkie or small truck. Built on roadworthy trailers manufactured in South Africa, these units are equipped with reliable Tier 3 engines for optimal performance.

## **WHOLE TREE CHIPPERS**

Bandit's whole tree chipper range is built using advanced global technology, over 35 years of industry experience, and international expertise to deliver high-quality, reliable whole tree chippers.

## **HORIZONTAL GRINDERS**

Bandit's range of horizontal grinders, also known as wood recyclers, is built with premium First World components, backed by global expertise, and proven through over 20 years of reliable performance in South Africa.

## **STUMP GRINDERS**

Bandit's stump grinder range includes everything from compact, handlebar-controlled units ideal for backyard projects to large, self-propelled track machines designed for high-production land clearing.

**HAND-FED WOOD CHIPPER**

# **BANDIT INTIMIDATOR™ 10XC PTO**



254 mm Towable Hand-Fed Drum Chipper  
High-productivity, low-cost PTO chipping for  
tree care and agriculture.

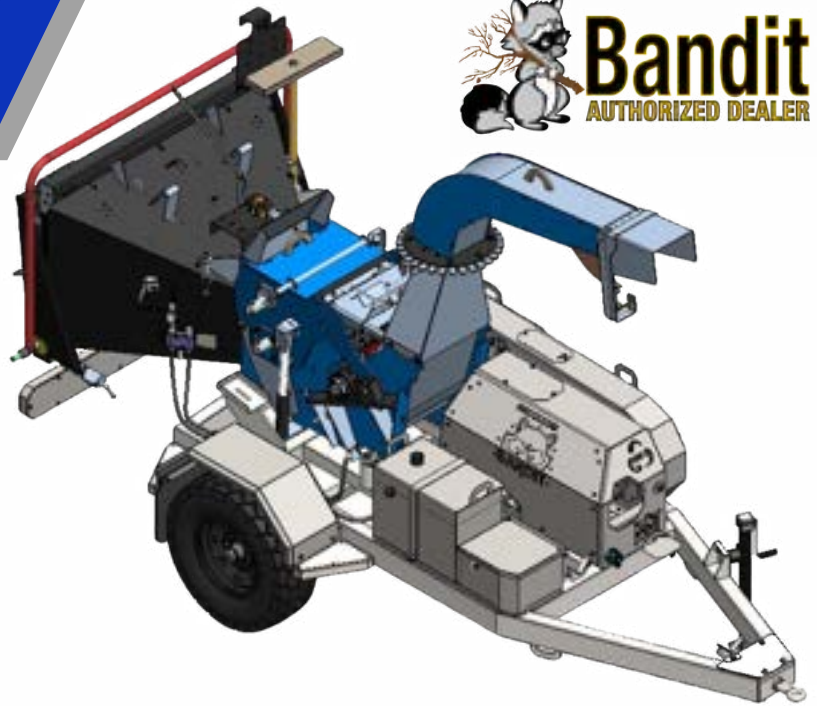

## **PERFORMANCE FEATURES**

**Power Slot:** Enhances airflow/throwing power, while simplifying unplugging access.

**Auto-Feed System:** Self-contained hydraulics optimise feed rate via tractor RPM.

**Feed System:** Oversized Ø400 mm spring loaded single hydraulic driven infeed roller on swivel arm for heavy material.

**Wide Profile Infeed:** Large 765 x 1375 mm hopper with spring loaded fold-down lid.

**Onboard:** Hydraulics and electrical system.

## **SAFETY & RELIABILITY**

**Rope/Line Shear:** Standard device to cut lines entering the chipper.

**Last Chance Cables:** Immediate feed stop/reverse emergency pull-cables.

**Safety Control Bar:** 3-sided wrap-around infeed direction control.

**Warranty:** 1yr/2,000hr machine coverage and 5yr/3,000hr 'GUTS' warranty.

**Local Build:** Localised engineering with 55% local content.

## **TECHNICAL SPECIFICATIONS**

CATEGORY	SPECIFICATION
Capacity	254 mm (10")
Infeed Opening	420 x 305 mm
PTO Power	45-80 hp / 35-60 kW
Drum / Blades	336 mm wide Drum; 2 Reversible Blades
Max Production	± 70-120 m <sup>3</sup> typical up to 240 m <sup>3</sup> / 8-hour day
Weight / Axle / Tyre Size	2,000 kg / 2,500 kg unbraked axle / 245/70R 16" tyres
Dimensions	4,300 (L) x 1,850 (W) x 2,600 (H) mm (Closed Hopper Lid)
Discharge	360° manual swivel; 305 mm adjustable chip deflector



## HAND-FED WOOD CHIPPER

# BANDIT INTIMIDATOR™ 10XC DIESEL



254 mm Towable Hand-Fed Drum Chipper  
High-productivity, cost-effective diesel  
chipper for tree care, municipalities, and  
agriculture.

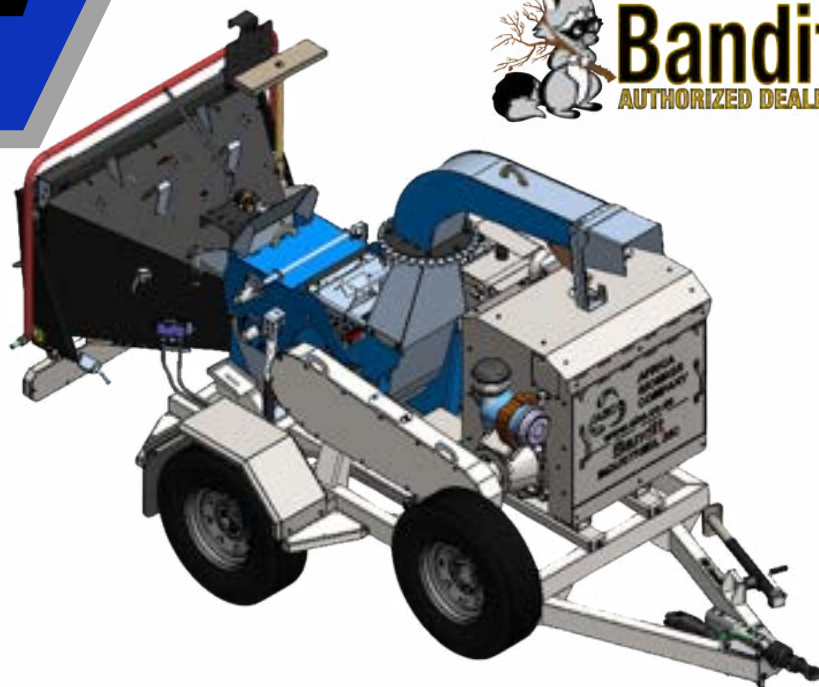

## PERFORMANCE FEATURES

**Power Slot:** Enhances airflow/throwing power, while simplifying unplugging access.

**Auto-Feed System:** Self-contained hydraulics optimise feed rate via engine RPM.

**Feed System:** Oversized Ø400 mm spring loaded single hydraulic driven infeed roller on swivel arm for heavy material.

**Wide Profile Infeed:** Large 765 x 1,375 mm hopper with spring loaded fold-down lid.

## SAFETY & RELIABILITY

**Last Chance Cables:** Immediate feed stop/reverse emergency pull-cables.

**Safety Control Bar:** 3-sided wrap-around infeed direction control.

**Warranty:** 1yr/2,000hr machine coverage and 5yr/3,000hrs 'GUTS' warranty.

**Local Build:** Localised engineering with 55% local content.

## TECHNICAL SPECIFICATIONS

CATEGORY	SPECIFICATION
Capacity	254 mm (10")
Infeed Opening	420 x 305 mm
Engine Power	Perkins 404C 22T / 56 hp / 42 kW
Fuel / Tank Capacity	Diesel / 70 L
Drum / Blades	336 mm wide Drum; 2 Reversible Blades
Max Production	± 80 m³ typical up to 160 m³ / 8-hour day
Weight / Axle / Tyre Size	2,550 kg / 3,000 kg braked axle / 7.50R16LT tyres
Dimensions	4,550 (L) x 2,100 (W) x 2,600 (H) mm (Closed Hopper Lid)
Discharge	360° manual swivel; 305 mm adjustable chip deflector

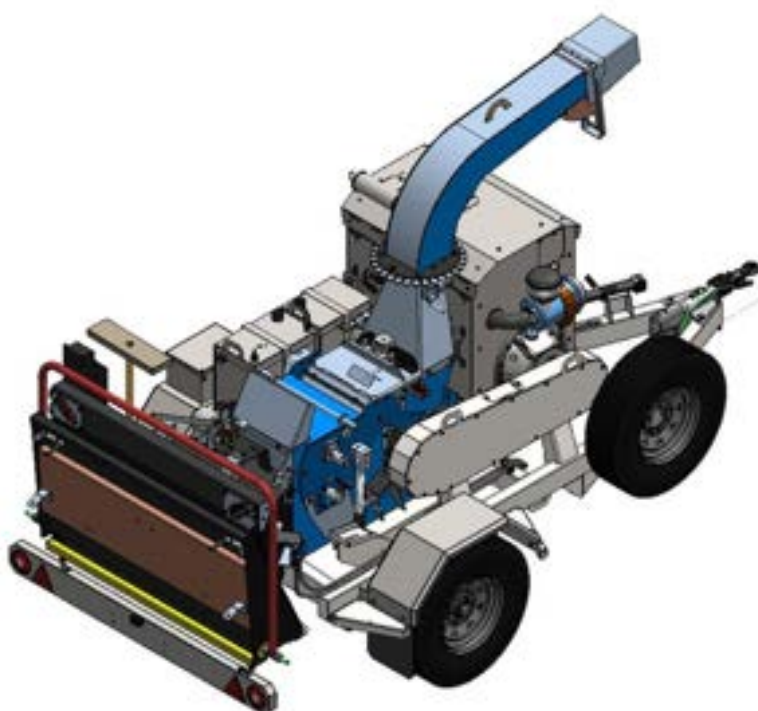

## HAND-FED WOOD CHIPPER

# BANDIT INTIMIDATOR™ 10XC BLUELINE



254 mm Towable Hand-Fed Drum Chipper  
Exceptional productivity and durability for tree care professionals, municipalities, and farmers.

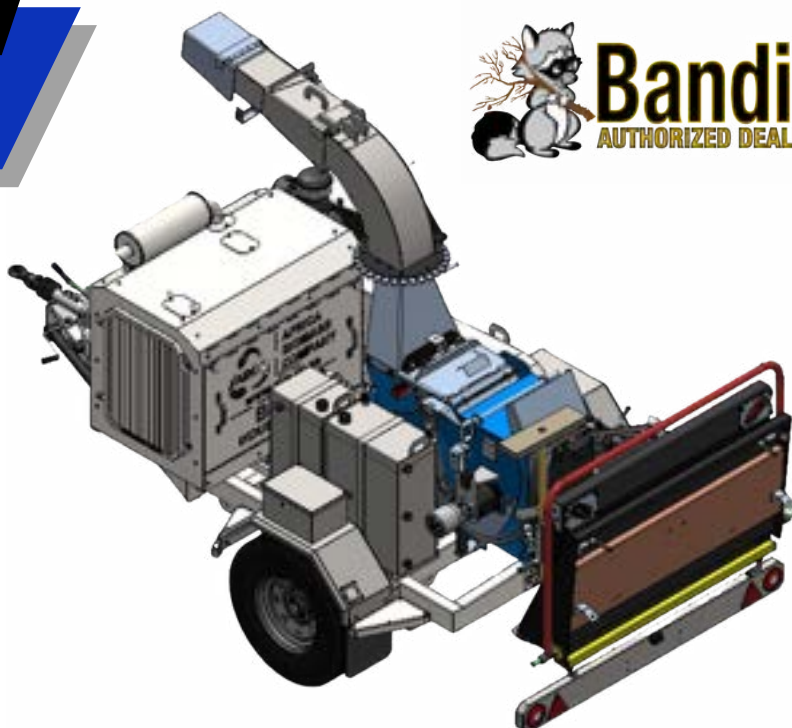

## PERFORMANCE FEATURES

**Power Slot:** Enhances airflow/throwing power, while simplifying unplugging access.

**Auto-Feed System:** Self-contained hydraulics optimise feed rate via engine RPM.

**Feed System:** Oversized Ø400 mm spring loaded single hydraulic driven infeed roller on swivel arm with lift/pressure cylinder for heavy material.

**Height adjustable chute:** For precision chip distribution to the ground or back of truck.

**Wide Profile Infeed:** Large 765 x 1,375 mm hopper with spring loaded fold-down lid.

## SAFETY & RELIABILITY

**Last Chance Cables:** Immediate feed stop/reverse emergency pull-cables.

**Safety Control Bar:** 3-sided wrap-around infeed direction control.

**Warranty:** 1yr/2,000hr machine coverage and 5yr/3,000hrs 'GUTS' warranty.

**Local Build:** Localised engineering with 55% local content.

## TECHNICAL SPECIFICATIONS

CATEGORY	SPECIFICATION
Capacity	254 mm (10")
Infeed Opening	420 x 305 mm
Engine Power	Perkins 1104C-44/ 85 hp / 64 kW
Fuel / Tank Capacity	Diesel / 80 L
Drum / Blades	336 mm wide Drum; 2 Reversible Blades
Max Production	± 130 m <sup>3</sup> typical up to 260 m <sup>3</sup> / 8-hour day
Weight / Axle / Tyre Size	2,750 kg / 3,000 kg braked axle / 7.50R16LT tyres
Dimensions	4,550 (L) x 2,100 (W) x 2,600 (H) mm (Closed Hopper Lid)
Discharge	360° manual swivel; 305 mm adjustable chip deflector

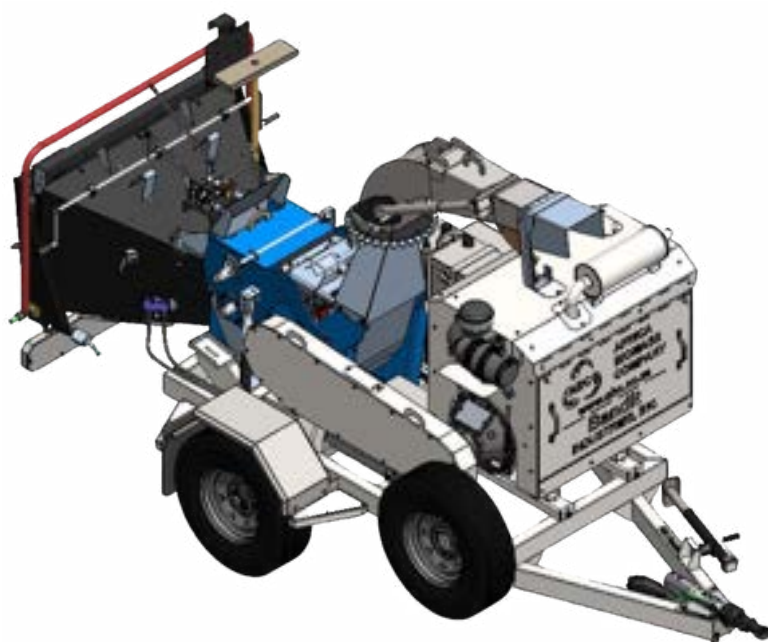

**HAND-FED WOOD CHIPPER**

**BANDIT INTIMIDATOR™**

**12XPC PTO**



305 mm Towable Hand-Fed Drum Chipper  
High-productivity, low-cost PTO chipping for tree care and agriculture.



## PERFORMANCE FEATURES

**Power Slot:** Enhances airflow/throwing power, while simplifying unplugging access.

**Auto-Feed System:** Self-contained hydraulics optimise feed rate via PTO RPM.

**Dual-Feed System:** Dual-feed wheel with slide box with lift/down-pressure cylinder for heavy material.

**Wide Profile Infeed:** Large 781 x 1,372 mm hopper with fold-down lid.

**Onboard:** Hydraulics and electrical system.

## SAFETY & RELIABILITY

**Rope/Line Shear:** Standard device to cut lines entering the chipper.

**Last Chance Cables:** Immediate feed stop/reverse emergency pull-cables.

**Safety Control Bar:** 3-sided wrap-around infeed direction control.

**Warranty:** 1yr/2,000hr machine coverage and 5yr/3,000hr 'GUTS' warranty.

**Local Build:** Localised engineering with 55% local content.

## TECHNICAL SPECIFICATIONS

CATEGORY	SPECIFICATION
Capacity	305 mm (12")
Infeed Opening	432 x 362 mm
PTO Power	50-85 hp / 37-65 kW
Drum / Blades	476 mm wide Drum; 4 Reversible Blades
Max Production	± 75-130 m <sup>3</sup> typical, up to 260 m <sup>3</sup> / 8-hour day
Weight / Axle / Tyre Size	2,000 kg / 2,500 kg unbraked axle / 245/70R 16" tyres
Dimensions	4,000 (L) x 1,850 (W) x 2,500 (H) mm (Closed Hopper Lid)
Discharge	360° manual swivel; 305 mm adjustable chip deflector



# HAND-FED WOOD CHIPPER

## BANDIT INTIMIDATOR™ 12XPC DIESEL



305 mm Towable Hand-Fed Drum Chipper  
High-productivity, cost-effective diesel chipper for tree care, municipalities, and agriculture.



### PERFORMANCE FEATURES

**Power Slot:** Enhances airflow/throwing power, while simplifying unplugging access.

**Auto-Feed System:** Self-contained hydraulics optimise feed rate via engine RPM.

**Dual-Feed System:** Dual-feed with slide box with lift/down-pressure cylinder for heavy material.

**Wide Profile Infeed:** Large 781 x 1,372 mm hopper with fold-down lid.

### SAFETY & RELIABILITY

**Rope/Line Shear:** Standard device to cut lines entering the chipper.

**Last Chance Cables:** Immediate feed stop/reverse emergency pull-cables.

**Safety Control Bar:** 3-sided wrap-around infeed direction control.

**Warranty:** 1yr/2,000hr machine coverage and 5yr/3,000hr 'GUTS' warranty.

**Local Build:** Localised engineering with 55% local content.

## TECHNICAL SPECIFICATIONS

CATEGORY	SPECIFICATION
Capacity	305 mm (12")
Infeed Opening	432 x 362 mm
Engin Power	Perkins 404C 22T / 60 hp / 44 kW
Fuel / Tank Capacity	Diesel / 60 L
Drum / Blades	476 mm wide Drum; 4 Reversible Blades
Max Production	± 90 m <sup>3</sup> typical, up to 180 m <sup>3</sup> / 8-hour day
Weight / Axle / Tyre Size	2,550 kg / 3,000 kg braked axle / 7.50R16LT tyres
Dimensions	4,500 (L) x 2,100 (W) x 2,600 (H) mm (Closed Hopper Lid)
Discharge	360° manual swivel; 305 mm adjustable chip deflector



## HAND-FED WOOD CHIPPER

# BANDIT INTIMIDATOR™ 12XPC BLUELINE



305 mm Towable Hand-Fed Drum Chipper  
Exceptional productivity and durability for tree care professionals, municipalities, and farmers.



## PERFORMANCE FEATURES

**Power Slot:** Enhances airflow/throwing power, while simplifying unplugging access.

**Auto-Feed System:** Self-contained hydraulics optimise feed rate via engine RPM.

**Dual-Feed System:** Dual-feed wheel with slide box with lift/down-pressure cylinder for heavy material.

**Wide Profile Infeed:** Large 781 x 1,372 mm hopper with fold-down lid.

## SAFETY & RELIABILITY

**Rope/Line Shear:** Standard device to cut lines entering the chipper.

**Last Chance Cables:** Immediate feed stop/reverse emergency pull-cables.

**Safety Control Bar:** 3-sided wrap-around infeed direction control.

**Warranty:** 1yr/2,000hr machine coverage; 5yr/3,000hr 'GUTS' warranty.

**Local Build:** Localised engineering with 55% local content.

## TECHNICAL SPECIFICATIONS

CATEGORY	SPECIFICATION
Capacity	305 mm (12")
Infeed Opening	432 x 362 mm
Engine / Power	Perkins 1104C-44T / 99 hp / 74 kW
Fuel / Tank Capacity	Diesel / 60 L
Drum / Blades	476 mm wide Drum; 4 Reversible Blades
Max Production	± 150 m <sup>3</sup> typical, up to 300 m <sup>3</sup> / 8-hour day
Weight / Axle / Tyre Size	2,900 kg / 3,000 kg braked axle / 7.50R16LT tyres
Dimensions	4,500 (L) x 2,100 (W) x 2,600 (H) mm (Closed Hopper Lid)
Discharge	360° manual swivel; 305 mm adjustable chip deflector



**HAND-FED WOOD CHIPPER**

## **BANDIT INTIMIDATOR™ 15XPC PTO**



**381 mm Towable Hand-Fed Drum Chipper**  
High-productivity, low-cost PTO chipping for tree care professionals and agriculture.



## **PERFORMANCE FEATURES**

**Power Slot:** Enhances airflow/throwing power, while simplifying unplugging access.

**Auto-Feed System:** Self-contained hydraulics optimise feed rate via PTO RPM.

**Dual-Feed System:** Dual-feed wheel with slide box with lift/down-pressure cylinder for heavy material.

## **SAFETY & RELIABILITY**

**Rope/Line Shear:** Standard device to cut lines entering the chipper.

**Last Chance Cables:** Immediate feed stop/reverse emergency pull-cables.

**Safety Control Bar:** 3-sided wrap-around infeed direction control.

**Warranty:** 1yr/2,000hr machine coverage and 5yr/3,000hr 'GUTS' warranty.

**Local Build:** Localised engineering with 55% local content.

## **TECHNICAL SPECIFICATIONS**

CATEGORY	SPECIFICATION
Capacity	381 mm (15")
Infeed Opening	473 x 438 mm
PTO Power	73-130 hp / 55-97.5 kW
Drum / Blades	Drum Style; 4 Reversible Blades
Max Production	± 110-90 m <sup>3</sup> typical, up to 300 m <sup>3</sup> / 8-hour day
Weight / Axle / Tyre Size	2,500 kg / unbraked axle 245/70R 16" tyres
Dimensions	4,200 (L) x 1,850 (W) x 2,700 (H) mm (Closed Hopper Lid)
Discharge	360° manual swivel; 305 mm adjustable chip deflector



## HAND-FED WOOD CHIPPER

# BANDIT INTIMIDATOR™ 15XPC INFEED



381 mm Towable Hand-Fed Drum Chipper with Infeed Conveyor

Designed for tree care and land clearing professionals needing to chip larger, more limby material.



## PERFORMANCE FEATURES

**Power Slot:** Enhances airflow/throwing power, while simplifying unplugging access.

**Auto-Feed System:** Self-contained hydraulics optimise feed rate via engine RPM.

**Dual-Feed System:** Steel infeed conveyor with slide box with feed wheel with lift/down-pressure cylinder for heavy material.

**Fuel Efficiency:** Synchronised feeding reduces idle time, cutting fuel costs by up to 30%.

## SAFETY & RELIABILITY

**Rope/Line Shear:** Standard device to cut lines entering the chipper.

**Last Chance Cables:** Immediate feed stop/reverse emergency pull-cables.

**Safety Control Bar:** 3-sided wrap-around infeed direction control.

**Warranty:** 1yr/2,000hr machine coverage and 5yr/3,000hr 'GUTS' warranty.

**Local Build:** Localised engineering with 55% local content.

## TECHNICAL SPECIFICATIONS

CATEGORY	SPECIFICATION
Capacity	381 mm (15")
Infeed Opening	474 x 438 mm
Engine / Power	Perkins 1104C 44T/ TA / 123 hp / 92 kW
Fuel / Tank Capacity	Diesel / 60 L
Drum / Blades	Drum Style; 4 Reversible Blades
Max Production	± 220 m <sup>3</sup> typical, up to 300 m <sup>3</sup> / 8-hour day
Weight / Axle / Tyre Size	3,800 kg / 3,500 kg braked axle / 235/75R 17.5" tyres
Dimensions	5,400 (L) x 2,100 (W) x 2,800 (H) mm
Discharge	360° manual swivel; 305 mm adjustable chip deflector



# HAND-FED WOOD CHIPPER

## BANDIT INTIMIDATOR™ 15XPC BLUELINE



381 mm Towable Hand-Fed Drum Chipper  
Designed for the demanding needs of tree care and  
land clearing professionals.



### PERFORMANCE FEATURES

**Power Slot:** Enhances airflow/throwing power, while simplifying unplugging access.

**Auto-Feed System:** Self-contained hydraulics optimise feed rate via engine RPM.

**Dual-Feed System:** Dual-feed wheel slide box with down-pressure for heavy material.

**Fuel Efficiency:** Synchronised feeding reduces idle time, cutting fuel costs by up to 30%.

### SAFETY & RELIABILITY

**Rope/Line Shear:** Standard device to cut lines entering the chipper.

**Last Chance Cables:** Immediate feed stop/reverse emergency pull-cables.

**Safety Control Bar:** 3-sided wrap-around infeed direction control.

**Warranty:** 1yr/2,000hr machine coverage and 5yr/3,000hr 'GUTS' warranty.

### TECHNICAL SPECIFICATIONS

CATEGORY	SPECIFICATION
Capacity	381 mm (15")
Infeed Opening	473 x 438 mm
Engine / Power	Perkins 1104C 44T/ TA / 123 hp / 92 kW
Fuel / Tank Capacity	Diesel / 60 L
Drum / Blades	476 mm wide Drum; 4 Reversible Blades
Max Production	± 180 m <sup>3</sup> typical, up to 360 m <sup>3</sup> / 8-hour day
Weight / Axle / Tyre Size	3,200 kg / 3,500 kg braked axle / 235/75R 17.5" tyres
Dimensions	4,600 (L) x 2,100 (W) x 2,750 (H) mm (Closed Hopper Lid)
Discharge	Height adjustable chute. Hydraulic swivel and chip deflector.



## HAND-FED WOOD CHIPPER

# BANDIT INTIMIDATOR™ 18XP DIESEL



457 mm Towable Hand-Fed Drum Chipper  
High-productivity, heavy-duty diesel chipper  
designed for forestry, tree care and land clearing  
professionals.



## PERFORMANCE FEATURES

**Power Slot:** Enhances airflow/throwing power, while simplifying unplugging access.

**Auto-Feed System:** Self-contained hydraulics optimise feed rate via engine RPM.

**Dual-Feed System:** Dual-feed wheel with slide box with lift/down-pressure cylinder for heavy material.

**Fuel Efficiency:** Synchronised feeding reduces idle time, cutting fuel costs by up to 30%.

## SAFETY & RELIABILITY

**Rope/Line Shear:** Standard device to cut lines entering the chipper.

**Last Chance Cables:** Immediate feed stop/reverse emergency pull-cables.

**Safety Control Bar:** 3-sided wrap-around infeed direction control.

**Warranty:** 1yr/2,000hr machine coverage and 5yr/3,000hr 'GUTS' warranty.

**Local Build:** Localised engineering with 55% local content.

## TECHNICAL SPECIFICATIONS

CATEGORY	SPECIFICATION
Capacity	457 mm (18")
Infeed Opening	520 x 529 mm
Engine / Power	Perkins 1106D 70TA / 172 hp / 129 kW
Fuel / Tank Capacity	Diesel / 145 L
Drum / Blades	Drum Style, 4 Reversible Blades
Max Production	± 260 m <sup>3</sup> typical, up to 520 m <sup>3</sup> / 8-hour day
Weight / Axle / Tyre Size	5,250 kg / 4,000 kg unbraked axle / 235/75R 17.5" tyres
Dimensions	5,500 (L) x 2,330 (W) x 2,950 (H) mm (Closed Hopper Lid)
Discharge	360° manual swivel; 305 mm adjustable chip deflector



## HAND-FED WOOD CHIPPER

# BANDIT INTIMIDATOR™ 18XP INFEED



### 457 mm Towable Hand-Fed Drum Chipper

A top choice for forestry, tree care, and land clearing professionals needing to chip larger, more limby material.



## PERFORMANCE FEATURES

**Power Slot:** Enhances airflow/throwing power, while simplifying unplugging access.

**Auto-Feed System:** Self-contained hydraulics optimise feed rate via engine RPM.

**Dual-Feed System:** Steel infeed conveyor with slide box with feed wheel with lift/down-pressure cylinder for heavy material.

**Fuel Efficiency:** Synchronised feeding reduces idle time, cutting fuel costs by up to 30%.

## SAFETY & RELIABILITY

**Control:** Remote or tether controlled.

**Warranty:** 1yr/2,000hr machine coverage and 5yr/3,000hr 'GUTS' warranty.

**Local Build:** Localised engineering with 55% local content.

## TECHNICAL SPECIFICATIONS

CATEGORY	SPECIFICATION
Capacity	457 mm (18")
Infeed Opening	520 x 529 mm
Engine / Power	Perkins 1106D 70TA / 172 hp / 129 kW
Fuel / Tank Capacity	Diesel / 145 L
Drum / Blades	Drum Style; 4 Reversible Blades
Max Production	± 310 m <sup>3</sup> typical, up to 620 m <sup>3</sup> / 8-hour day
Weight / Axle / Tyre Size	5,250 kg / 4,000 kg unbraked axle / 235/75R 17.5" tyres
Dimensions	5,500 (L) x 2,330 (W) x 2,950 (H) mm
Discharge	360° manual swivel; 305 mm adjustable chip deflector



## BANDIT INTIMIDATOR™ 19XP DIESEL



### 482.6 mm Towable Hand-Fed Drum Chipper

A top choice for forestry, tree care, and land clearing professionals needing to chip larger, more limby material.



## PERFORMANCE FEATURES

**Power Slot:** Enhances airflow/throwing power, while simplifying unplugging access.

**Auto-Feed System:** Self-contained hydraulics optimise feed rate via engine RPM.

**Dual-Feed System:** Dual-feed wheel with slide box with lift/down-pressure cylinder for heavy material.

**Fuel Efficiency:** Synchronised feeding reduces idle time, cutting fuel costs by up to 30%.

## SAFETY & RELIABILITY

**Rope/Line Shear:** Standard device to cut lines entering the chipper.

**Last Chance Cables:** Immediate feed stop/reverse emergency pull-cables.

**Safety Control Bar:** 3-sided wrap-around infeed direction control.

**Warranty:** 1yr/2,000hr machine coverage and 5yr/3,000hr 'GUTS' warranty.

## TECHNICAL SPECIFICATIONS

CATEGORY	SPECIFICATION
Capacity	482.6 mm (19")
Infeed Opening	520 x 530 mm
Engine / Power	Cummins, Cat / 139-229 hp / 102-165 kW
Fuel / Tank Capacity	Diesel / ± 113.5 L
Drum / Blades	Drum Style; 4 Reversible Blades
Max Production	200-330 m <sup>3</sup> typical, up to 660 m <sup>3</sup> / 8-hour day
Weight / Axle / Tyre Size	4,454 - 5,227 kg
Dimensions	6,325 (L) x 2,362 (W) x 2,640 (H) mm
Discharge	360° manual swivel; 305 mm adjustable chip deflector



**HAND-FED WOOD CHIPPER**

# **BANDIT INTIMIDATOR™ 21XP DIESEL**



**533 mm Towable Hand-Fed Drum Chipper**  
Designed for professionals requiring exceptional production, high throughput, and the ability to process large whole trees.



## **PERFORMANCE FEATURES**

**Massive Feed Power:** The Slide Box Feed System delivers 4,920 kg of pulling force for effortless feeding of large materials and reduced trimming labour.

**High-Capacity Processing:** Class-leading 667 mm x 622 mm throat opening handles whole trees and heavy clearing with ease.

**Optimised Chip Quality:** 940 mm drum produces consistent, high-quality chips while extending blade life.

**Hydraulic Versatility:** 360° hydraulic swivel discharge with lift cylinder for improved down pressure and smoother feeding.

## **SAFETY & RELIABILITY**

**Standard Auto-Feed:** Automatic reversing system prevents stalling and ensures smooth, continuous operation.

**Robust Construction:** Reinforced drum and dual in-feed rollers deliver durability in tough conditions.

**Efficient Maintenance:** Cleanout door design allows quicker servicing and reliable performance.

**Warranty:** 1yr/2,000hr machine coverage and 5yr/3,000hr 'GUTS' warranty.

## **TECHNICAL SPECIFICATIONS**

CATEGORY	SPECIFICATION
Capacity	533 mm (21")
Infeed Opening	667 x 622 mm
Engine / Power	Cummins, Cat / 170-350 hp / 127-262 kW
Fuel / Tank Capacity	Diesel
Drum / Blades	Drum Style; 4 Reversible Blades
Max Production	260-520 m <sup>3</sup> typical, up to 1,040 m <sup>3</sup> / 8-hour day
Weight / Axle / Tyre Size	± 6,985 kg
Dimensions	5,820 (L) x 2,550 (W) x 3,070 (H) mm (Closed Hopper Lid)
Discharge	360° manual swivel; 305 mm adjustable chip deflector



**559 mm Towable Whole Tree Chipper**

This entry-level whole tree chipper is designed for professionals requiring exceptional production, high throughput, and the ability to process large whole trees. Popular among tree services and land clearing contractors.



\*SOLD WITHOUT LOADER / LOADER IS OPTIONAL

**PERFORMANCE FEATURES**

**Massive Feed Power:** The Slide Box Feed System delivers 7,257 kg of pulling force, enabling effortless feeding of large materials and reducing trimming labour.

**High-Capacity Processing:** Class-leading 667 mm x 622 mm throat opening handles whole trees and heavy clearing with ease.

**Optimised Chip Quality:** 940 mm drum produce consistent, high-quality chips while extending blade life.

**Advanced Control:** Standard wireless radio remote with tether back-up controls all feed system and discharge functions.

**SAFETY & RELIABILITY**

**Standard Auto-Feed:** Automatic reversing system prevents stalling and ensures smooth, continuous operation.

**Robust Construction:** Reinforced drum and dual in-feed rollers deliver durability in tough conditions.

**Efficient Maintenance:** Cleanout door design allows quicker servicing and reliable performance.

**Warranty:** 1yr/2,000hr machine coverage and 5yr/3,000hr 'GUTS' warranty.

**TECHNICAL SPECIFICATIONS**

CATEGORY	SPECIFICATION
Capacity	559 mm (22")
Infeed Opening	667 x 622 mm
Engine / Power	Cummins, Cat / 275-350 hp / 205-262 kW
Fuel / Tank Capacity	Diesel / 227.13 L
Drum / Blades	Ø940 mm Drum Style; 4 Reversible Blades
Max Production	400-520 m <sup>3</sup> typical, up to 1,040 m <sup>3</sup> / 8-hour day
Weight / Axle / Tyre Size	± 8,935 kg
Dimensions	6,706 (L) x 2,591 (W) x 2,845 (H) mm
Discharge	360° manual swivel; with hydraulic chip deflector





**559 mm Track Whole Tree Chipper**

This entry-level whole tree chipper is designed for professionals requiring exceptional production, high throughput, and the ability to process large whole trees. Popular among tree services and land clearing contractors.



**PERFORMANCE FEATURES**

**Massive Feed Power:** The Slide Box Feed System utilises dual feed wheels, an 813 mm x 686 mm top wheel and an 813 mm x 270 mm bottom wheel, for industry-leading pulling and crushing power.

**High-Capacity Processing:** Class-leading 667 mm x 622 mm throat opening handles whole trees and heavy clearing with ease.

**Go-Anywhere Mobility:** Available with a Caterpillar 315 L steel track undercarriage (600 mm) for travelling over varied terrain, reducing the need to skid material.

**Advanced Control:** A wireless radio remote control with tether back-up is standard, managing all track and feed system functions, including engine E-stop.

**SAFETY & RELIABILITY**

**Standard Auto-Feed:** Automatic reversing system prevents stalling and ensures smooth, continuous operation.

**Robust Construction:** Reinforced drum and dual in-feed rollers deliver durability in tough conditions.

**Efficient Maintenance:** Cleanout door design allows quicker servicing and reliable performance.

**Warranty:** 1yr/2,000hr machine coverage and 5yr/3,000hr 'GUTS' warranty.

**TECHNICAL SPECIFICATIONS**

CATEGORY	SPECIFICATION
Capacity	559 mm (22")
Infeed Opening	667 x 622 mm
Engine / Power	Cummins, Cat / 415-525 hp / 309.5-386 kW
Fuel / Tank Capacity	Diesel / 567 L
Drum / Blades	Ø940 mm Drum Style; 4 Reversible Blades
Max Production	620-770 m <sup>3</sup> typical, up to 1,540 m <sup>3</sup> / 8-hour day
Weight	± 18,144-20,865 kg (Model Dependant)
Dimensions	6,401 (L) x 3,099 (W) x 3,505 (H) mm
Discharge	Hydraulic up/down & side-to-side deflector



**584 mm Whole Tree Chipper**

Built for high-volume wood processing. Its powerful feed system and large chipper drum ensure efficient and consistent chipping of whole trees and large branches. This model is ideal for biomass production, land clearing, and forestry operations.



**PERFORMANCE FEATURES**

**Infeed:** Standard 2.29 m in-feed chain quickly conveys material to the in-feed rollers.

**Slide Box Feed System:** Provides unmatched pulling and compressing power, reducing the need to reposition material.

**Efficient Discharge:** Packs trailer fuller without the need for fuel-chugging chip accelerators or auxiliary throwers.

**SAFETY & RELIABILITY**

**Heavy-Duty Construction:** Solid welded steel frame with premium components for maximum uptime.

**Global Dealer Support:** Backed by an extensive worldwide parts and service network.

**Warranty:** 1yr/2,000hr machine coverage and 5yr/3,000hr 'GUTS' warranty.

**TECHNICAL SPECIFICATIONS**

CATEGORY	SPECIFICATION/TOWABLE
Capacity	584 mm (23")
Infeed Opening	660 x 762 mm
Engine / Power	CAT C18 / 755-800 hp / 555-588 kW
Fuel / Tank Capacity	Diesel / 492 L
Chipper Shaft	152 mm in diameter
Feed System	Slide box with (1) 914 mm (W) x Ø686 mm top wheel & (1) 914 mm (W) x Ø270 mm bottom wheel
Discharge	Stationary swivel with hydraulic deflector
Blades	15,9 mm thick x 140 mm wide x 254 mm long in 6 pockets
Max Production	± 1000-1,200 m <sup>3</sup> typical / 8-hour day
Weight	± 19,958 kg
Dimensions	11,735 (L) x 2,777 (W) x 3,902 (H) mm

CATEGORY	SPECIFICATION/TRACK
Capacity	584 mm (23")
Infeed Opening	660 x 762 mm
Engine / Power	CAT C18 / 755 hp / 555 kW
Fuel / Tank Capacity	Diesel / 1,135 L
Chipper Shaft	152 mm in diameter
Feed System	Slide box with (1) 914 mm (W) x Ø686 mm top wheel & (1) 914 mm (W) x Ø270 mm bottom wheel
Discharge	Stationary swivel with hydraulic deflector
Blades	15,9 mm thick x 140 mm wide x 254 mm long in 6 pockets
Max Production	± 1,000-1,200 m <sup>3</sup> typical / 8-hour day
Weight	± 24,948 kg
Dimensions	8,740 (L) x 3,350 (W) x 3,710 (H) mm

**BANDIT MINI BEAST® 1425**



**360 mm Towable Horizontal Grinder**

A compact yet robust grinder, ideal for small-scale grinding operations, towable by a small 4-ton truck, making it highly portable.



**PERFORMANCE FEATURES**

**Efficient Milling:** Inward-turning cutter mill improves material flow and processing speed.

**Powerful Infeed:** 2.13 m friction chain with 400 mm top roller handles bulky feedstock.

**Durable Tooling:** 14 carbide-tipped tools for high-speed, long-life performance.

**Cleaner Output:** Discharge conveyor with a magnetic head pulley removes metal.

**SAFETY & RELIABILITY**

**Heavy-Duty Build:** Robust chassis and mill housing for demanding applications.

**Easy Service:** Quick screen changes and ground-level maintenance access.

**Smart Controls:** Radio remote and auto-feed prevent overload and improve safety.

**Warranty:** 1yr/2,000hr BANDIT INDUSTRIES INC. limited warranty.

**TECHNICAL SPECIFICATIONS**

CATEGORY	SPECIFICATION/TOWABLE
Capacity	360 mm
Infeed Opening	508 x 635 mm
Engine / Power	CAT C4.4B, T3 / 140 hp / 103 kW
Fuel / Tank Capacity	Diesel / 151.4 L
Feed Wheel	(1) 400 mm in diameter
Infeed Conveyor (Steel)	Single speed, 2,134 (L) x 610 (W) mm
Discharge Conveyor	457 mm wide cleated rubber
Stacking Height	2,134 mm high
Teeth	14
Weight	5,670 kg
Max Production	140-210 m <sup>3</sup> / 8-hour day
Dimensions	6,504 (L) x 2,515 (W) x 2,845 (H) mm

CATEGORY	SPECIFICATION/TOWABLE
Capacity	360 mm
Infeed Opening	508 x 635 mm
Engine / Power	CAT C4.4B, T3 / 140 hp / 103 kW
Fuel / Tank Capacity	Diesel / 151.4 L
Feed Wheel	(1) 400 mm in diameter
Infeed Conveyor (Steel)	Single speed, 2,134 (L) x 610 (W) mm
Discharge Conveyor	457 mm wide cleated rubber
Stacking Height	2,134 mm high
Teeth	14
Weight	8,074 kg
Max Production	140-210 m <sup>3</sup> / 8-hour day
Dimensions	7,544 (L) x 2,572 (W) x 2,921 (H) mm

**BANDIT THE BEAST® 1680XP**



**458 mm Towable Horizontal Grinder**  
 Perfect for light site clearing operations. This versatile machine efficiently processes trees, brush, leaves, sawmill residues, and pallets into valuable mulch and fuel wood.



**PERFORMANCE FEATURES**

**Efficient Milling:** Beast® cuttermill with unique cutterbody holder ensures uniform output with lower energy use.

**Versatile Processing:** Handles slash, chips, bark, C&D waste, tree waste, and limbs for premium mulch production.

**Compact Manoeuvrability:** Easy transport into tight sites; track model accesses rough terrain.

**High Productivity:** Achieves target size on first pass, reducing fuel use and wear.

**SAFETY & RELIABILITY**

**Heavy-Duty Construction:** Solid welded steel frame with premium components for maximum uptime.

**Global Dealer Support:** Backed by an extensive worldwide parts and service network.

**Track Mobility:** Caterpillar steel undercarriage allows on-site positioning directly at the material source.

**TECHNICAL SPECIFICATIONS**

CATEGORY	SPECIFICATION/TOWABLE
Capacity	458 mm
Infeed Opening	457 x 1,320 mm
Engine / Power	300-365 hp / 224-274 kW
Fuel / Tank Capacity	Diesel / 379 L
Feed Wheel	(1) 406 mm in diameter
Infeed Conveyor	Single speed, 3,886 (L) x 1,320 (W) mm
Discharge Conveyor	1,219 mm wide cleated rubber
Stacking Height	4,343 mm high
Teeth	26
Weight	14,288 kg
Max Production	± 450-550 m <sup>3</sup> / 8-hour day
Dimensions	11,400 (L) x 2,591 (W) x 3,710 (H) mm

CATEGORY	SPECIFICATION/TOWABLE
Capacity	458 mm
Infeed Opening	457 x 1,320 mm
Engine / Power	300-365 hp / 224-274 kW
Fuel / Tank Capacity	Diesel / 379 L
Feed Wheel	(1) 406 mm in diameter
Infeed Conveyor	Single speed, 3,886 (L) x 1,320 (W) mm
Discharge Conveyor	1,219 mm wide cleated rubber
Stacking Height	4,343 mm high
Teeth	26
Weight	17,046 kg
Max Production	± 450-550 m <sup>3</sup> / 8-hour day
Dimensions	8,103 (L) x 2,515 (W) x 3,810 (H) mm

## BANDIT THE BEAST® 2680XP TRACK



### 660 mm Track Horizontal Grinder

This grinder offers flagship versatility for a wide range of applications. With a powerful design, it serves tree services, municipalities, and recycling yards.



## PERFORMANCE FEATURES

**Efficient Milling:** Beast® cuttermill with unique cutterbody holder ensures uniform output with lower energy use.

**Versatile Processing:** Handles slash, chips, bark, C&D waste, tree waste, and limbs for premium mulch production.

**Compact Manoeuvrability:** Easy transport into tight sites; track model accesses rough terrain.

**High Productivity:** Achieves target size on first pass, reducing fuel use and wear.

## SAFETY & RELIABILITY

**Heavy-Duty Construction:** Solid welded steel frame with premium components for maximum uptime.

**Global Dealer Support:** Backed by an extensive worldwide parts and service network.

**Track Mobility:** Caterpillar steel undercarriage allows on-site positioning directly at the material source.

## TECHNICAL SPECIFICATIONS

CATEGORY	SPECIFICATION
Capacity	890 mm
Infeed Opening	890 x 1,520 mm
Engine / Power	540-755 hp / 405-555 kW
Fuel / Tank Capacity	Diesel / 1,098 L
Feed Wheel	(1) 510 mm in diameter
Infeed Conveyor	Six speed, 3,660 (L) x 1,524 (W) mm
Discharge Conveyor	1,220 mm wide cleated rubber
Stacking Height	5,791 mm high
Teeth	30 or 60
Max Production	800-1,100 m³ typical / 8-hour day
Weight	30,844 kg
Dimensions	10,520 (L) x 2,970 (W) x 3,785 (H) mm



**BANDIT HM6420**



**1,020 mm Track Horizontal Hammermill Grinder**  
 The HM6420 offers flagship versatility and is specifically designed as a solution for grinding applications that may contain contaminants.



**PERFORMANCE FEATURES**

**Heavy-Duty Hammermill:** 44.45 mm custom-rolled drum skin with a 177.8 mm ultrasonically tested alloy steel main shaft.

**High-Power Infeed:** Slat conveyor delivers 8,165 kg of pulling force; floating feed wheel adds 7,711 kg of pull and up to 7,847 kg of hydraulic downforce.

**Fast, Adjustable Feed:** A proportional feed system controls intake at 25-40 m/min – among the fastest available.

**Quick Screen Access:** Three top-access screens with removable cradle for fast, external changeovers.

**SAFETY & RELIABILITY**

**Impact Detection System (IDS):** Standard equipment designed to limit damage from contaminants. Upon impact, the system idles the engine, disengages the clutch, and reverses the feed.

**Patent-Pending Pocket System:** Hammer holders are recessed into mill pockets and secured by a top plate with six hex bolts for maximum durability and easy maintenance.

**Superior Mobility:** Equipped with a Caterpillar 325EL steel track undercarriage, controlled via radio remote with two-speed drive settings for rough terrain positioning.

**TECHNICAL SPECIFICATIONS**

CATEGORY	SPECIFICATION
Capacity	1,020 mm
Infeed Opening	1,020 x 1,630 mm
Engine / Power	CAT C32 / 1,200 hp / 894.8 kW
Fuel / Tank Capacity	Diesel / 1,893 L
Feed Wheel	(1) 970 mm in diameter
Infeed Conveyor	Slat Style, 4,875 (L) x 1,625 (W) mm
Discharge Conveyor	1,420 mm wide
Stacking Height	5,050 mm high
Hammermill	1,270 mm in diameter x 1,620 (W) mm
Hammer tips	20 carbide-infused inserts
Weight	46,266 kg
Dimensions	13,510 (L) x 3,420 (W) x 3,650 (H) mm



The aggressive, all-terrain track stump grinder for professionals. The Bandit SG-40 is a cost-effective, high-performance stump grinder. Featuring a belt-driven cutter wheel, improved operator visibility, and a rugged track system for terrain beyond rubber-tired access.



## PERFORMANCE FEATURES

**Optimal Visibility:** 3-position pivoting console for clear viewing of the grinding action from any stump position.

**Aggressive Cutting:** Belt-driven cutter wheel powers through stumps with ease, leading its size class.

**Advanced Manoeuvrability:** Fast travel speeds and low-impact tracks minimise site disturbance.

**Operator-Friendly Controls:** Dual joysticks for travel and a single joystick for cutter functions boost productivity.

**Optional:** New revolution wheel with 24 teeth

**Optional:** Hydraulic, beltless cutter-wheel drive, eliminating belt maintenance.

## SAFETY & RELIABILITY

**Durable Track Drive:** All-terrain performance with easy side-bolt adjustment.

**EFI Engine Reliability:** Easy-start EFI petrol engine delivering consistent torque across stump sizes.

**Precise Engineering:** Accurate belt adjustments and robust instrumentation for long-term reliability.

## TECHNICAL SPECIFICATIONS

CATEGORY	SPECIFICATION
Diameter	Ø457 mm cutter wheel with 8 teeth
Cutter Swing	1,194 mm
Cutter Depth	305 mm
Cutter Height	559 mm
Drum / Blades	Ø940 mm Drum Style; 4 Reversible Blades
Engine Power	38 hp / 28.3 kW
Weight	680.5 kg
Dimensions	2,553 (L) x 737 (W) x 1,220 (H) mm



**BANDIT MODEL SG-75 TRACK**



The preferred solution with aggressive grinding capabilities and ease of maintenance.

The SG-75 is a high-powered track stump grinder, designed for maximum power, stability, and debris control, featuring a gearbox-driven cutter wheel and a 74 hp engine that makes it easy to tackle large stumps.



**PERFORMANCE FEATURES**

**Gearbox Drive:** Direct power to the cutter wheel for efficient large-diameter grinding.

**Expandable Track Platform:** Tracks widen to 1,397 mm for stability and retract to 889 mm for gate access.

**Radio Remote Control:** Wireless remote manages travel, swing speed, and cutter engagement.

**Superior Chip Containment:** Fold-down curtains concentrate debris, minimising cleanup.

**SAFETY & RELIABILITY**

**Maintenance-Free Clutch:** Warner electric clutch for simple, maintenance-free engagement.

**Super Sweep System:** Bandit's Super Sweep optimises grinding efficiency.

**Optional Grading Blade:** Available blade enhances site restoration and debris control.

**TECHNICAL SPECIFICATIONS**

CATEGORY	SPECIFICATION
Diameter	690 mm
Cutter Swing	2,032 mm
Cutter Depth	584 mm
Cutter Height	787 mm
Engine Power	Kohler T4 / 74 hp / 55.2 kW
Weight	2,086.5 kg
Dimensions	3,404 (L) x 1,905 (W) x 2,057 (H) mm







## ABC'S PARTS STORE, WORKSHOP & FIELD SERVICES

**Africa Biomass Company** is one of the best go-to wood chipper equipment sales and service agents in Africa. With a comprehensive understanding of the operational challenges of wood recycling in South Africa, ABC has established state-of-the-art facilities to service, repair and rebuild wood chipper equipment of any brand and size.

### THE X-FACTOR IN WOOD CHIPPERS

ABC is the authorised dealer for Bandit wood chippers in Africa. Bandit combines first-world technology and experience with African functionality. This makes Bandit the logical choice for wood chippers in Africa.

### ABC UNDERSTANDS WOOD RECYCLING AND WOOD CHIPPERS

With an intimate understanding of the operational challenges of wood recycling in South Africa, ABC established state-of-the-art facilities to service, repair and rebuild wood chipper equipment of any make and size.

Africa Biomass Company's facilities are manned by a remarkable team of well-experienced and suitably qualified engineers, technicians, and artisans. An equally remarkable team of field-service technicians delivers repairs, maintenance, and parts to a client's site to optimise uptime and efficiency.

### CUSTOM-BUILT SABS APPROVED TRAILERS

Each Bandit hand-fed chipper from Africa Biomass Company is mounted on a SABS-approved trailer that is specifically designed for the model hand-fed chipper it carries. These trailers are built to perfection at ABC's head office in Worcester.

### GEOGRAPHICAL FOOTPRINT

Africa Biomass Company operates in all 9 provinces of South Africa and also across the borders into sub-Saharan Africa, including Namibia, Botswana, Zimbabwe, Mozambique, Zambia, Malawi, Tanzania, Kenya as well as Nigeria.



**Bandit**  
AUTHORIZED DEALER  
SINCE 1983



**QUALITY &  
AND SERVICE  
GUARANTEED**

**TALK TO US.**

Email: [info@abc.co.za](mailto:info@abc.co.za)  
Telephone: +27 23 342 1212  
Telephone: 0860 246 627 (BIO MAS)  
Address: 3 Sennet Street, Worcester, 6850, South Africa

Website: [www.abc.co.za](http://www.abc.co.za)

Follow us on social media  
Facebook: Africa Biomass Company  
YouTube: Africa Biomass Company  
Instagram: @africabiomasscompany

All specifications, dimensions, and options are subject to change without notice and were accurate at the time of publication.

© 2026 Africa Biomass Company (Pty) Ltd. | All rights reserved.

IMPORTED AND DISTRIBUTED BY



**AFRICA  
BIOMASS  
COMPANY**

[www.abc.co.za](http://www.abc.co.za)